

Distribuitor în România - Gada Ceramic București
Str. Vlad Județu 48
<https://gadaceramic.ro/produs/gresie-ardesia/>

Ardesia

GRES PORCELLANATO IN MASSA
FULL BODY PORCELAIN TILES
GRES CERAME PLEINE MASSE
VOLLMASSE-FEINSTEINZEUG
PORCELÁNICO COMPACTO TODO MASA
ОДНОТОННЫЙ КЕРАМОГРАНИТ



Civilization of Beauty

Distribuitoare în România - Gada Ceramic București
Str. Vlad Județu 48
<https://gadaceramic.ro/produs/gresie-ardesia/>

Ardesia

GRES PORCELLANATO IN MASSA
FULL BODY PORCELAIN TILES
GRES CERAME PLEINE MASSE
VOLLMASSE-FEINSTEINZEUG
PORCELÁNICO COMPACTO TODO MASA
ОДНОТОННЫЙ КЕРАМОГРАНИТ



Indoor 10 mm: 80x80 31 $\frac{1}{2}$ "x31 $\frac{1}{2}$ " nat. ret. / 60x120 24"x48" nat. ret. / 60x60 24"x24" nat. ret. / 30x60 12"x24" nat. ret. / 30,5x60,5 12"x24" nat. / Mosaico 30x30 12"x12" nat. ret. / Muretto 3D 15x61 6"x24" nat.

Outdoor 10 mm R11: 80x80 31 $\frac{1}{2}$ "x31 $\frac{1}{2}$ " nat. ret. / 60x120 24"x48" nat. ret.

Outdoor 20 mm R11: 80x80 31 $\frac{1}{2}$ "x31 $\frac{1}{2}$ " nat. ret. / 40x120 16"x48" nat. ret.

Naturale e rettificato. Natural and rectified. Naturel et rectifié.
Natur Oberfläche und kalibriert. Natural y rectificado. Натуральный ректифицированный.

Naturale. Natural. Naturel. Natur Natur. Natural. Натуральный.

Una nuova proposta ceramica ispirata alla struttura lievemente irregolare e al colore che contraddistinguono l'Ardesia, pietra sedimentaria da sempre molto apprezzata in architettura.
Una collezione elegante e multifunzionale, adatta a molteplici possibilità applicative, indoor e outdoor

A new ceramic offering inspired by the slightly uneven texture and colour of slate, a sedimentary stone that has always been much appreciated in architecture. An elegant, multipurpose collection, ideal for a wide range of applications, both indoors and out.

Une nouvelle proposition de céramique inspirée par la structure et la couleur légèrement irrégulières qui distinguent l'ardoise, une pierre sédimentaire depuis toujours très appréciée en architecture. Une collection élégante et multifonctionnelle, pour de nombreuses possibilités d'application, à l'intérieur comme à l'extérieur.

Ein neues keramisches Angebot, das von der leicht unregelmäßigen Struktur und von der Wärme inspiriert wurde, die den Schiefer kennzeichnen, ein seit jeher in der Architektur sehr geschätztes Sedimentgestein. Eine elegante und vielseitige Kollektion, die sich für vielfältige Anwendungsmöglichkeiten im Innen- und Außenbereich eignet.

Una nueva propuesta cerámica inspirada en la estructura ligeramente irregular y en el color que caracterizan a ardesia, piedra sedimentaria desde siempre muy apreciada en arquitectura. Una colección elegante y multifuncional, apropiada para múltiples posibilidades aplicativas en interiores y exteriores.

Новое предложение керамики, вдохновением для которой послужила слегка неровная структура и цвет, отличающие сланец (итал., Ardesia) - осадочный камень, который всегда очень ценился в архитектуре. Это - элегантная и многофункциональная коллекция, пригодная для многочисленных возможностей применения, как во внутренних, так и в наружных пространствах.

Distribuitoare în România - Gada Ceramic București
Str. Vlad Județu 48
<https://gadaceramic.ro/produs/gresie-ardesia/>

Ampia libertà di scelta.

FULL FREEDOM OF CHOICE.
UNE GRANDE LIBERTE DE CHOIX.
BREITE WAHLFREIHEIT.
AMPLIA LIBERTAD DE ELECCIÓN.
БОЛЬШАЯ СВОБОДА ВЫБОРА.

4 colori declinati in diversi formati disponibili nelle finiture indoor spessore 10 mm, outdoor 10 mm e 20 mm. Con Ardesia, la bellezza della pietra naturale si sposa alla versatilità e diventa materia che garantisce prestazioni eccellenti in tutti gli ambiti di intervento.

4 colours available in different sizes in a 10 mm thick version for the indoor finishes and 10 mm and 20 mm options for outdoor use. With Ardesia, the beauty of natural stone is combined with versatility, creating a material that guarantees excellent performance in all areas of use.

4 couleurs dans différents formats disponibles dans les finitions pour l'intérieur de 10 mm d'épaisseur, pour l'extérieur de 10 mm et de 20 mm. Avec Ardesia, la beauté de la pierre naturelle s'allie à la polyvalence et devient un matériau qui garantit d'excellentes performances dans tous les domaines d'intervention.

Verschiedene Formate, die in 4 Farben und Oberflächen für den Innenbereich in der Stärke von 10 mm und für den Außenbereich von 10 mm und 20 mm erhältlich sind. Mit Ardesia verbindet sich die Schönheit des Natursteins mit der Vielseitigkeit und wird zu einer Materie, die hervorragende Leistungen in allen Einsatzbereichen garantiert.

4 colores disponibles en variados formatos con acabados para interiores de 10 mm de espesor y para exteriores de 10 y 20 mm. Con Ardesia, la belleza de la piedra natural ofrece también versatilidad y se convierte en materia que garantiza prestaciones excelentes en todos los ámbitos de intervención.

4 цвета, предлагаемых в разных форматах с отделками для внутренних пространств толщиной 10 мм и для наружных толщиной 10 и 20 мм. Благодаря Ardesia красота природного камня совмещается с практичностью и становится таким материалом, который гарантирует великолепные характеристики во всем спектре выполняемых работ.



outdoor **20 mm** / R11 A+B+C

outdoor **10 mm** / R11 A+B+C

indoor **10 mm**

Distribuitoare în România - Gada Ceramic București
Str. Vlad Județu 48
<https://gadaceramic.ro/produs/gresie-ardesia/>

Armonie cromatiche tra indoor e outdoor.

HARMONY OF COLOUR INDOORS AND OUT.
DES HARMONIES CHROMATIQUES ENTRE L'INTERIEUR ET L'EXTERIEUR.
FARBLICHE HARMONIEN ZWISCHEN INNEN- UND AUSSENBEREICH.
ARMONÍAS CROMÁTICAS ENTRE INTERIORES Y EXTERIORES.
ЦВЕТОВАЯ ГАРМОНИЯ ВНУТРЕННИХ И НАРУЖНЫХ ПРОСТРАНСТВ.

La disponibilità di finiture e spessori appositamente pensati per le diverse destinazioni d'uso fa di Ardesia la scelta ideale per creare suggestivi effetti di continuità materica tra gli ambienti indoor e outdoor, sia nelle abitazioni private sia negli spazi commerciali.

The availability of finishes and thicknesses designed specifically for different uses makes Ardesia the ideal choice to create stunning continuity of material between indoor and outdoor spaces, in both homes and retail settings.

Grâce à la disponibilité de finitions et d'épaisseurs spécifiquement conçues pour différents usages, Ardesia représente le choix idéal pour créer des effets suggestifs de continuité matérielle entre l'intérieur et l'extérieur, dans les maisons et dans les espaces commerciaux.

Die Verfügbarkeit von Oberflächen und Stärken, die speziell für die verschiedenen Verwendungszwecke bestimmt sind, macht Ardesia zur idealen Wahl, um eindrucksvolle Effekte der materiellen Kontinuität zwischen den Innen- und Außenbereichen, sowohl in privaten Wohn- als auch in Gewerberäumen hervorzurufen.

La disponibilidad de acabados y espesores, especialmente previstos para las diferentes posibilidades de uso, hace de Ardesia la opción ideal para crear sugestivos efectos de continuidad material entre los ambientes interiores y exteriores, tanto en las habitaciones privadas como en los espacios comerciales.

Разнообразие отделки и толщины, которые были специально задуманы для различных сфер назначения, превращают Ardesia в наилучший выбор для создания великолепных эффектов непрерывности оформления во внутренних и наружных пространствах, как в частном жилье, так и на коммерческих объектах.

Indoor / Grigio 80x80 . 31 1/2"x31 1/2" Nat. Ret.
AVA Extraordinary Size Marmi Statuario 320x160 . 126"x63" Lap. Ret.
Outdoor / Grigio 80x80 . 31 1/2"x31 1/2" Nat. Ret. 20mm R11
Gradone bordo grip Grigio 40x80 . 16"x31 1/2" Nat. Ret. 20mm R11
Canalina Grigio 20x80 . 8"x31 1/2" Nat. Ret. 20mm R11



Gamma completa di pezzi speciali.

FULL RANGE OF TRIMS.
GAMME COMPLETE DE PIÈCES SPÉCIALES.
EINE UMFANGREICHE PALETTE VON FORMTEILEN.
GAMA COMPLETA DE PIEZAS ESPECIALES.
ПОЛНЫЙ АССОРТИМЕНТ СПЕЦИАЛЬНЫХ ИЗДЕЛИЙ.

La possibilità di effettuare interventi all'insegna della completezza progettuale è ulteriormente rafforzata da un'articolata gamma di pezzi speciali. Per arrivare ovunque, realizzando ambientazioni curate fin nei minimi particolari.

The possibility of creating total design projects is further facilitated by an extensive range of trims. Wherever you need to tile, there is an option, so you can create designs thought out to the smallest detail.

La possibilité de réaliser des interventions au nom de l'exhaustivité conceptuelle est intériorément renforcée par une gamme structurée de pièces spéciales. Pour arriver partout, en créant des décors avec le souci du détail.

Die Möglichkeit zum Ausführen der Maßnahmen im Zeichen der Vollständigkeit des Entwurfs wird weiter durch eine vielfältige Palette von Formteilen verstärkt. Um alle Stellen zu erreichen und in den kleinsten Details gepflegte Arrangements herzustellen.

La posibilidad de efectuar intervenciones a la enseña de la completión proyectual es ulteriormente confirmada por una amplia gama de piezas especiales. Para llegar a todo lugar, realizando ambientes cuidados hasta en sus más mínimos detalles.

Возможность выполнения работ без нарушения полноты проекта дополнительно подчеркивается ассортиментом специальных изделий. Чтобы охватить все, создавая интерьеры, продуманные в мельчайших подробностях.

Indoor / Grigio 80x80 . 31 ½"x31 ½" Nat. Ret.
Outdoor / Grigio 80x80 . 31 ½"x31 ½" Nat. Ret. 20mm R11
Gradone bordo grip Grigio 40x80 . 16"x31 ½" Nat. Ret. 20mm R11
Canalina Grigio 20x80 . 8"x31 ½" Nat. Ret. 20mm R11





Indoor / Grigio 80x80 . 31 1/2"x31 1/2" Nat. Ret.

Distribuitor în România - Gada Ceramic București
Str. Vlad Județu 48
<https://gadaceramic.ro/produs/gresie-ardesia/>

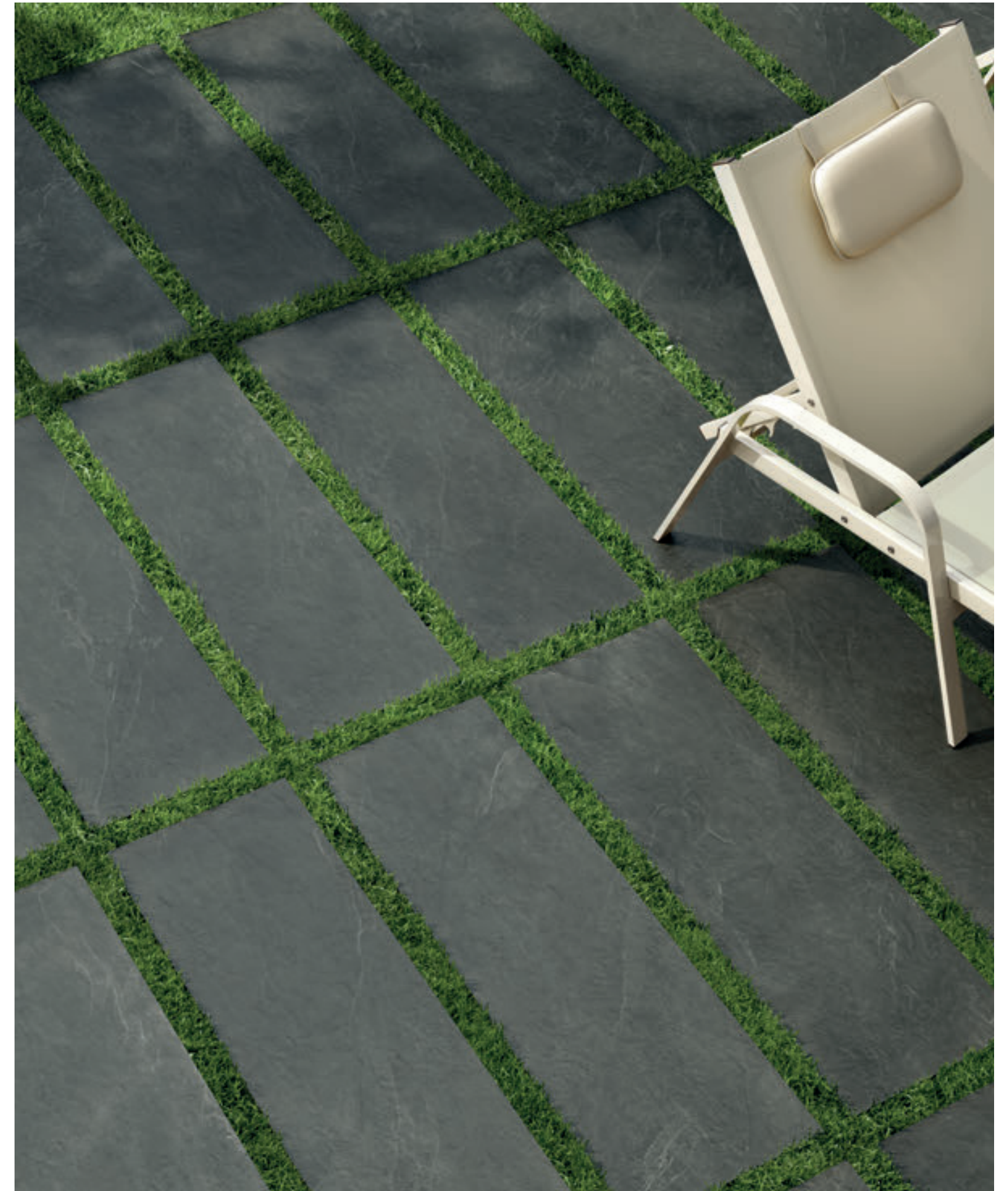

Outdoor / Grigio 40x120 . 16"x48" Nat. Ret. 20mm R11

Indoor / Bianco 30x60 . 12"x24" Nat. Ret. - Mosaico Cenere 30x30 . 12"x12" Nat. Ret.

Distribuitor în România - Gada Ceramic București
Str. Vlad Județu 48
<https://gadaceramic.ro/produs/gresie-ardesia/>



Distribuitor în România - Gada Ceramic București
Str. Vlad Județu 48
<https://gadaceramic.ro/produs/gresie-ardesia/>

Indoor / Cenere 60x120 . 24"x48" Nat. Ret. - 60x60 . 24"x24" Nat. Ret. - 30x60 . 12"x24" Nat. Ret.
Muretto 3D Cenere 15x61 . 6"x24" Nat.



Distribuitor în România - Gada Ceramic București
Str. Vlad Județu 48
<https://gadaceramic.ro/produs/gresie-ardesia/>

Indoor / Cenere 60x120 . 24"x48" Nat. Ret. - 60x60 . 24"x24" Nat. Ret. - 30x60 . 12"x24" Nat. Ret. - Muretto 3D Cenere 15x61 . 6"x24" Nat.



Indoor / Muretto 3D Cenere 15x61 . 6"x24" Nat.

Distribuitor în România - Gada Ceramic București
Str. Vlad Județu 48
<https://gadaceramic.ro/produs/gresie-ardesia/>

Indoor / Taupe 60x120 . 24"x48" Nat. Ret.



Distribuitor în România - Gada Ceramic București
Str. Vlad Județu 48

<https://gadaceramic.ro/produs/gresie-ardesia/>

Indoor / Taupe 80x80 . 31 ½"x31 ½" Nat. Ret. - Gradino costa retta Taupe 33x80x3,2h . 13"x31 ½" x1 ½" Nat. Ret.
Outdoor / Taupe 80x80 . 31 ½"x31 ½" Nat. Ret. 20mm R11
Gradone bordo grip Taupe 40x80 . 16"x31 ½" Nat. Ret. 20mm R11



Gres porcellanato in massa. Full body porcelain tiles. Grès cérame pleine masse.
Vollmasse-Feinsteinzeug, Porcelánico compacto todo masa. Однотонный керамогранит.

Naturale e rettificato. Natural and rectified. Naturel et rectifié. Natur Oberfläche und kalibriert. Natural y rectificado. Натуральный ректифицированный.
 Naturale. Natural. Naturel. Natur Natur. Natural. Натуральный.

SHADE SPECTRUM Low <input type="checkbox"/> Moderate <input checked="" type="checkbox"/> High <input type="checkbox"/> Random <input type="checkbox"/>	ANSI A 137.1: 2012	OUTDOOR 60x120, 80x80, 10 mm 40x120, 80x80: 20 mm
	WET DYNAMIC COEFFICIENT OF FRICTION	R11 A+B+C
	DCOF $\geq 0,42$	SCIVOLOSITÀ SLIPPERY GRADE



Gres porcellanato in massa. Full body porcelain tiles. Grès cérame pleine masse. Vollmasse-Feinsteinzeug. Porcelánico compacto todo masa. Однотонный керамогранит.

Naturale e rettificato. Natural and rectified. Naturel et rectifié. Natur Oberfläche und kalibriert. Natural y rectificado. Натуральный ректифицированный.

Naturale. Natural. Naturel. Natur Natur. Natural. Натуральный.

SHADE SPECTRUM

Low Moderate

High Random

ANSI A
137.L: 2012

WET DYNAMIC
COEFFICIENT
OF FRICTION





DCOF ≥ 0,42

OUTDOOR
R11
A+B+C

SCIVOLOSITÀ
SLIPPERY GRADE

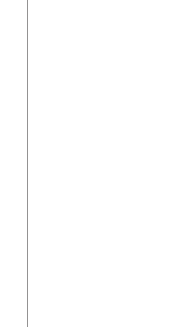

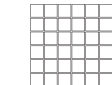
I N D O O R

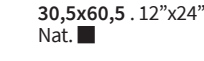
Spessore. Thickness. Epaisseur. Stärke. Espesor. Толщина. **10 mm**

 80x80 . 31 1/2"x31 1/2" Nat. Ret. <input type="checkbox"/> M089 137013 - Bianco 137015 - Cenere 137014 - Taupe 137016 - Grigio	 60x120 . 24"x48" Nat. Ret. <input type="checkbox"/> M105 137001 - Bianco 137003 - Cenere 137002 - Taupe 137004 - Grigio	 60x60 . 24"x24" Nat. Ret. <input type="checkbox"/> M083 137025 - Bianco 137027 - Cenere 137026 - Taupe 137028 - Grigio	 30x60 . 12"x24" Nat. Ret. <input type="checkbox"/> M081 137037 - Bianco 137039 - Cenere 137038 - Taupe 137040 - Grigio	 Mosaico 30x30 . 12"x12" Nat. Ret. <input type="checkbox"/> M135 137201 - Bianco 137203 - Cenere 137202 - Taupe 137204 - Grigio	 Muretto 3D 15x61 . 6"x24" Nat. <input checked="" type="checkbox"/> M083 137043 - Bianco 137045 - Cenere 137044 - Taupe 137046 - Grigio
 30,5x60,5 . 12"x24" Nat. <input checked="" type="checkbox"/> M073 137031 - Bianco 137033 - Cenere 137032 - Taupe 137034 - Grigio					

I N D O O R

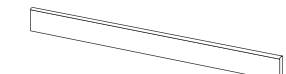
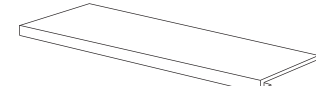
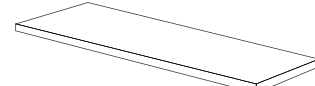
Spessore. Thickness. Epaisseur. Stärke. Espesor. Толщина. **10 mm**

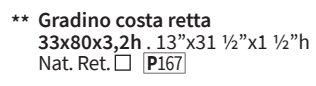
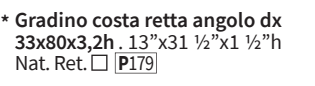
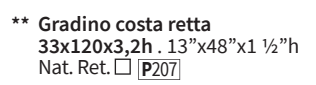
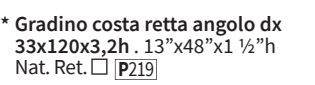
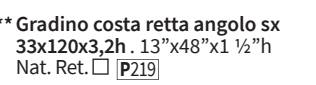
 Battiscopa 6,5x120 . 2 1/2"x48" Nat. Ret. <input type="checkbox"/> P029 137101 Bianco 137103 Cenere 137102 Taupe 137104 Grigio	 ** Gradino costa retta 33x60x3,2h . 13"x24"x1 1/2"h Nat. Ret. <input type="checkbox"/> P135 137301 Bianco 137304 Cenere 137307 Taupe 137310 Grigio	 ** Gradino costa retta angolo dx 33x60x3,2h . 13"x24"x1 1/2"h Nat. Ret. <input type="checkbox"/> P151 137302 Bianco 137305 Cenere 137308 Taupe 137311 Grigio	 ** Gradino costa retta angolo sx 33x60x3,2h . 13"x24"x1 1/2"h Nat. Ret. <input type="checkbox"/> P151 137303 Bianco 137306 Cenere 137309 Taupe 137312 Grigio
 ** Gradino costa retta 33x80x3,2h . 13"x31 1/2"x1 1/2"h Nat. Ret. <input type="checkbox"/> P167 137321 Bianco 137324 Cenere 137327 Taupe 137330 Grigio		 ** Gradino costa retta angolo dx 33x80x3,2h . 13"x31 1/2"x1 1/2"h Nat. Ret. <input type="checkbox"/> P179 137322 Bianco 137325 Cenere 137328 Taupe 137331 Grigio	
 ** Gradino costa retta 33x120x3,2h . 13"x48"x1 1/2"h Nat. Ret. <input type="checkbox"/> P207 137341 Bianco 137344 Cenere 137347 Taupe 137350 Grigio		 ** Gradino costa retta angolo dx 33x120x3,2h . 13"x48"x1 1/2"h Nat. Ret. <input type="checkbox"/> P219 137342 Bianco 137345 Cenere 137348 Taupe 137351 Grigio	
 ** Gradino costa retta angolo sx 33x120x3,2h . 13"x48"x1 1/2"h Nat. Ret. <input type="checkbox"/> P219 137343 Bianco 137346 Cenere 137349 Taupe 137352 Grigio			

O U T D O O R

Spessore. Thickness. Epaisseur. Stärke. Espesor. Толщина. **10 mm R11**

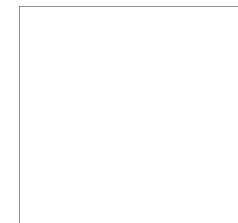
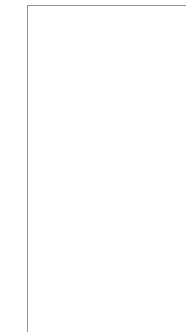
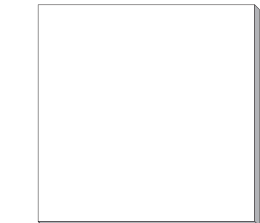
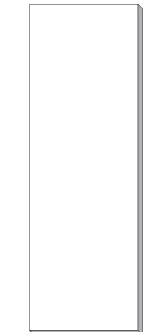

 80x80 . 31 1/2"x31 1/2" Nat. Ret. <input type="checkbox"/> R11 M089 137019 - Bianco 137021 - Cenere 137020 - Taupe 137022 - Grigio	 60x120 . 24"x48" Nat. Ret. <input type="checkbox"/> R11 M105 137007 - Bianco 137009 - Cenere 137008 - Taupe 137010 - Grigio	 80x80 . 31 1/2"x31 1/2" Nat. Ret. <input type="checkbox"/> 20 mm R11 M137 137057 - Bianco 137059 - Cenere 137058 - Taupe 137060 - Grigio	 40x120 . 16"x48" Nat. Ret. <input type="checkbox"/> 20 mm R11 M135 137050 - Bianco 137052 - Cenere 137051 - Taupe 137053 - Grigio
--	---	--	---

O U T D O O R 2 0 M M

Spessore. Thickness. Epaisseur. Stärke. Espesor. Толщина. **20 mm R11**

O U T D O O R

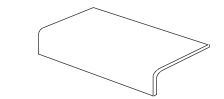
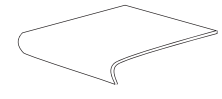
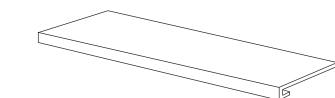
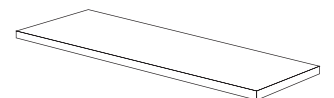
Spessore. Thickness. Epaisseur. Stärke. Espesor. Толщина. **10 mm R11**

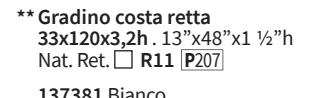
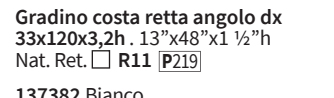
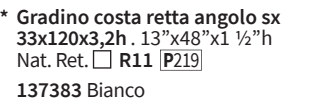
 Elemento a L 16x30,5x4,5h . 1 1/4"x12"x1 3/4"h Nat. <input checked="" type="checkbox"/> R11 P075 137161 Bianco 137163 Cenere 137162 Taupe 137164 Grigio	 Gradino piegato 30,5x34x5h . 12"x1 1/8"x2"h Nat. <input checked="" type="checkbox"/> R11 P085 137151 Bianco 137153 Cenere 137152 Taupe 137154 Grigio	
 ** Gradino costa retta 33x80x3,2h . 13"x31 1/2"x1 1/2"h Nat. Ret. <input type="checkbox"/> R11 P167 137361 Bianco 137364 Cenere 137367 Taupe 137370 Grigio	 ** Gradino costa retta angolo dx 33x80x3,2h . 13"x31 1/2"x1 1/2"h Nat. Ret. <input type="checkbox"/> R11 P179 137362 Bianco 137365 Cenere 137368 Taupe 137371 Grigio	 ** Gradino costa retta angolo sx 33x80x3,2h . 13"x31 1/2"x1 1/2"h Nat. Ret. <input type="checkbox"/> R11 P179 137363 Bianco 137366 Cenere 137369 Taupe 137372 Grigio
 ** Gradino costa retta 33x120x3,2h . 13"x48"x1 1/2"h Nat. Ret. <input type="checkbox"/> R11 P207 137381 Bianco 137384 Cenere 137387 Taupe 137390 Grigio	 ** Gradino costa retta angolo dx 33x120x3,2h . 13"x48"x1 1/2"h Nat. Ret. <input type="checkbox"/> R11 P219 137382 Bianco 137385 Cenere 137388 Taupe 137391 Grigio	 ** Gradino costa retta angolo sx 33x120x3,2h . 13"x48"x1 1/2"h Nat. Ret. <input type="checkbox"/> R11 P219 137383 Bianco 137386 Cenere 137389 Taupe 137392 Grigio

Tra i fondi di spessore 10 e 20 mm non si garantisce l'abbinabilità. - We cannot guarantee tonal matches between the same background tiles with different thickness (10 or 20 mm). Les assortiments des tons ne sont pas garantis pour les fonds d'une épaisseur de 10 et 20 mm. - Bei Bodenfliesen mit einer Stärke von 10 und 20 mm wird keine Einheitlichkeit der Farbtöne garantiert. Para los fondos de espesor 10 y 20 mm no se garantiza la combinabilidad de tonalidades. - Для фоновой плитки толщиной 10 и 20 мм не гарантирована цветовая сочетаемость.

** A disposizione solo su richiesta. Tempi di consegna: 30gg. - Available upon request only. Delivery terms: 30 days. - Disponible seulement sur requête. Délais de livraison: 30 jours. Verfügbar auf Anfrage. Lieferzeit: 30 Tage. - Disponible sólo bajo pedido. Plazo de entrega: 30 días. - Изготавливается только по специальной заявке. Срок поставки: 30 дней.

Per il gradino non si garantisce la stessa tonalità del fondo. - We cannot guarantee that the shade of the stair tile will be the same as the background tile. Pour la marche, nous ne garantissons pas la même tonalité du fond. - Für die Stufe wird nicht der gleiche Farbton der Grundfliese garantiert. Para el peldaño no se garantiza el mismo tono del fondo. - Для ступени не гарантирована одинаковость тона с фоном.

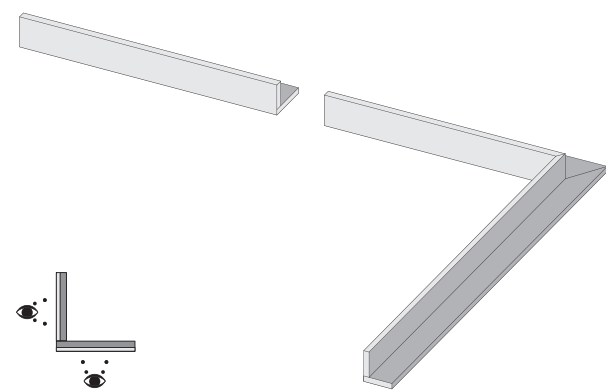

Bordo L "A" . L-shaped border "A"
Bord en L « A » . Rand L "A"- Förmig
10x120x10h . 4"x48"x4"h
Nat. Ret. □ 20 mm R11 [P193](#)

137517 Bianco
137518 Cenere
137519 Taupe
137520 Grigio

Bordo L "A" dx . L-shaped border "A"
Bord en L « A » . Rand L "A"- Förmig
10x120x10h . 4"x48"x4"h
Nat. Ret. □ 20 mm R11 [P223](#)

137521 Bianco
137522 Cenere
137523 Taupe
137524 Grigio

Bordo L "A" sx . L-shaped border "A"
Bord en L « A » . Rand L "A"- Förmig
10x120x10h . 4"x48"x4"h
Nat. Ret. □ 20 mm R11 [P223](#)

137525 Bianco
137526 Cenere
137527 Taupe
137528 Grigio

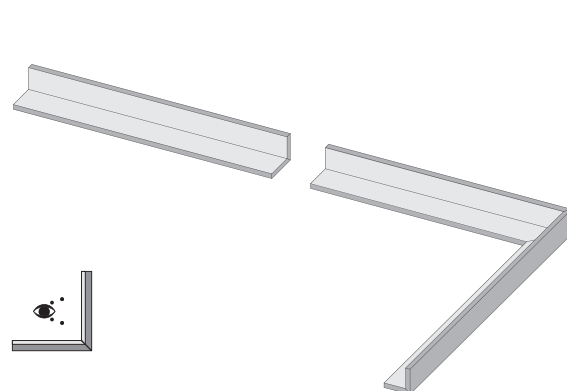

Bordo L "B" . L-shaped border "B"
Bord en L « B » . Rand L "B"- Förmig
10x120x10h . 4"x48"x4"h
Nat. Ret. □ 20 mm R11 [P257](#)

137541 Bianco
137542 Cenere
137543 Taupe
137544 Grigio

Bordo L "B" dx . L-shaped border "B"
Bord en L « B » . Rand L "B"- Förmig
10x120x10h . 4"x48"x4"h
Nat. Ret. □ 20 mm R11 [P277](#)

137545 Bianco
137546 Cenere
137547 Taupe
137548 Grigio

Bordo L "B" sx . L-shaped border "B"
Bord en L « B » . Rand L "B"- Förmig
10x120x10h . 4"x48"x4"h
Nat. Ret. □ 20 mm R11 [P277](#)

137549 Bianco
137550 Cenere
137551 Taupe
137552 Grigio

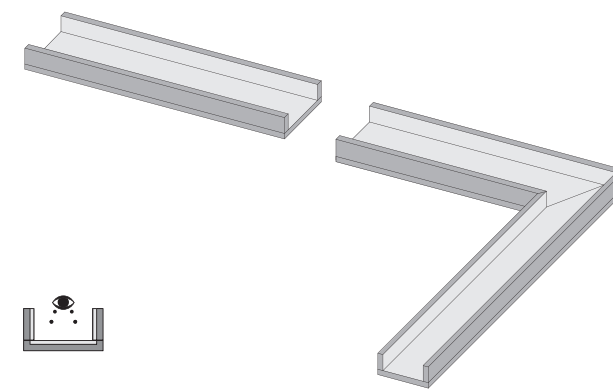

Canalina . Channel
Caniveaux . Überlauferinne
20x80x8h . 8"x31 1/2"x3"h
Nat. Ret. □ 20 mm R11 [P189](#)

137577 Bianco
137578 Cenere
137579 Taupe
137580 Grigio

Canalina dx . Channel
Caniveaux . Überlauferinne
20x80x8h . 8"x31 1/2"x3"h
Nat. Ret. □ 20 mm R11 [P217](#)

137581 Bianco
137582 Cenere
137583 Taupe
137584 Grigio

Canalina sx . Channel
Caniveaux . Überlauferinne
20x80x8h . 8"x31 1/2"x3"h
Nat. Ret. □ 20 mm R11 [P217](#)

137585 Bianco
137586 Cenere
137587 Taupe
137588 Grigio

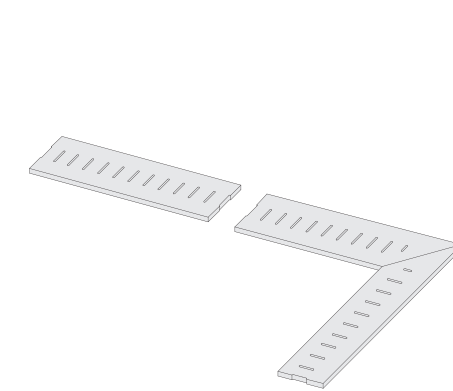

Griglia 20 . Drainage grid 20
Drainage grille 20 . Rinnenabdeckung 20
20x60 . 8"x24"
Nat. Ret. □ 20 mm R11 [P205](#)

137757 Bianco
137758 Cenere
137759 Taupe
137760 Grigio

Griglia 20 dx . Drainage grid 20
Drainage grille 20 . Rinnenabdeckung 20
20x60 . 8"x24"
Nat. Ret. □ 20 mm R11 [P205](#)

137761 Bianco
137762 Cenere
137763 Taupe
137764 Grigio

Griglia 20 sx . Drainage grid 20
Drainage grille 20 . Rinnenabdeckung 20
20x60 . 8"x24"
Nat. Ret. □ 20 mm R11 [P205](#)

137765 Bianco
137766 Cenere
137767 Taupe
137768 Grigio

Bordo L "A" . L-shaped border "A"
Bord en L « A » . Rand L "A"- Förmig
10x80x10h . 4"x31 1/2"x4"h
Nat. Ret. □ 20 mm R11 [P159](#)

137529 Bianco
137530 Cenere
137531 Taupe
137532 Grigio

Bordo L "A" dx . L-shaped border "A"
Bord en L « A » . Rand L "A"- Förmig
10x80x10h . 4"x31 1/2"x4"h
Nat. Ret. □ 20 mm R11 [P187](#)

137533 Bianco
137534 Cenere
137535 Taupe
137536 Grigio

Bordo L "A" sx . L-shaped border "A"
Bord en L « A » . Rand L "A"- Förmig
10x80x10h . 4"x31 1/2"x4"h
Nat. Ret. □ 20 mm R11 [P187](#)

137537 Bianco
137538 Cenere
137539 Taupe
137540 Grigio

Bordo L "B" . L-shaped border "B"
Bord en L « B » . Rand L "B"- Förmig
10x80x10h . 4"x31 1/2"x4"h
Nat. Ret. □ 20 mm R11 [P201](#)

137553 Bianco
137554 Cenere
137555 Taupe
137556 Grigio

Bordo L "B" dx . L-shaped border "B"
Bord en L « B » . Rand L "B"- Förmig
10x80x10h . 4"x31 1/2"x4"h
Nat. Ret. □ 20 mm R11 [P229](#)

137557 Bianco
137558 Cenere
137559 Taupe
137560 Grigio

Bordo L "B" sx . L-shaped border "B"
Bord en L « B » . Rand L "B"- Förmig
10x80x10h . 4"x31 1/2"x4"h
Nat. Ret. □ 20 mm R11 [P229](#)

137561 Bianco
137562 Cenere
137563 Taupe
137564 Grigio

Canalina . Channel
Caniveaux . Überlauferinne
20x120x8h . 8"x48"x3"h
Nat. Ret. □ 20 mm R11 [P255](#)

137565 Bianco
137566 Cenere
137567 Taupe
137568 Grigio

Canalina dx . Channel
Caniveaux . Überlauferinne
20x120x8h . 8"x48"x3"h
Nat. Ret. □ 20 mm R11 [P271](#)

137569 Bianco
137570 Cenere
137571 Taupe
137572 Grigio

Canalina sx . Channel
Caniveaux . Überlauferinne
20x120x8h . 8"x48"x3"h
Nat. Ret. □ 20 mm R11 [P271](#)

137573 Bianco
137574 Cenere
137575 Taupe
137576 Grigio

Griglia 20 . Drainage grid 20
Drainage grille 20 . Rinnenabdeckung 20
20x80 . 8"x31 1/2"
Nat. Ret. □ 20 mm R11 [P239](#)

137769 Bianco
137770 Cenere
137771 Taupe
137772 Grigio

Griglia 20 dx . Drainage grid 20
Drainage grille 20 . Rinnenabdeckung 20
20x80 . 8"x31 1/2"
Nat. Ret. □ 20 mm R11 [P239](#)

137773 Bianco
137774 Cenere
137775 Taupe
137776 Grigio

Griglia 20 sx . Drainage grid 20
Drainage grille 20 . Rinnenabdeckung 20
20x80 . 8"x31 1/2"
Nat. Ret. □ 20 mm R11 [P239](#)

137777 Bianco
137778 Cenere
137779 Taupe
137780 Grigio

ATTENZIONE: Per particolari installazioni potrebbero essere necessari articoli ed accessori specifici non presenti in questo catalogo. Per queste esigenze prego riferirsi direttamente al referente commerciale La Fabbrica. - N.B. Particular items and accessories not listed in this catalogue may be required for certain laying methods. For these needs, please contact the La Fabbrica sales directly. **ATTENTION:** Pour les installations particulières, certains articles et accessoires particuliers qui ne sont pas indiqués dans ce catalogue pourraient être nécessaires. Dans ces cas-là, nous vous prions de vous référer directement à la référence commerciale La Fabbrica. - ACHTUNG: Für besondere Installationen können besondere Artikel oder Sonderzubehör notwendig sein, die nicht im vorliegenden Katalog aufgeführt sind. Wenden Sie sich bitte in diesen Fällen direkt an den Vertrieb von La Fabbrica. - ATENCION: para instalaciones particulares podrían requerirse artículos y accesorios específicos que no están presentes en este catálogo. Para tales casos rogamos contactar directamente al representante comercial de La Fabbrica. - ВНИМАНИЕ: Для особых применений могут быть необходимы специальные артикулы и аксессуары, не представленные в данном каталоге. По поводу этих вопросов просим вас обращаться непосредственно к менеджеру коммерческого отдела компании La Fabbrica.

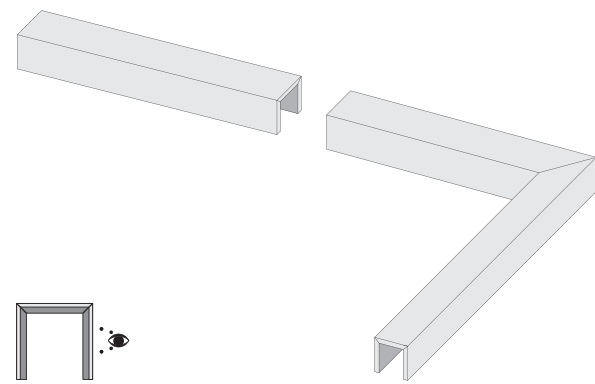

Cordolo . U-Border
Bordure . Rand U-Förmig
13x120x13h . 5"x48"x5"h
Nat. Ret. □ 20 mm R11 **P291**

137589 Bianco
137590 Cenere
137591 Taupe
137592 Grigio

Cordolo dx . U-Border
Bordure . Rand U-Förmig
13x120x13h . 5"x48"x5"h
Nat. Ret. □ 20 mm R11 **P303**

137593 Bianco
137594 Cenere
137595 Taupe
137596 Grigio

Cordolo sx . U-Border
Bordure . Rand U-Förmig
13x120x13h . 5"x48"x5"h
Nat. Ret. □ 20 mm R11 **P303**

137597 Bianco
137598 Cenere
137599 Taupe
137600 Grigio

Cordolo . U-Border
Bordure . Rand U-Förmig
13x80x13h . 5"x31 ½"x5"h
Nat. Ret. □ 20 mm R11 **P229**

137601 Bianco
137602 Cenere
137603 Taupe
137604 Grigio

Cordolo dx . U-Border
Bordure . Rand U-Förmig
13x80x13h . 5"x31 ½"x5"h
Nat. Ret. □ 20 mm R11 **P257**

137605 Bianco
137606 Cenere
137607 Taupe
137608 Grigio

Cordolo sx . U-Border
Bordure . Rand U-Förmig
13x80x13h . 5"x31 ½"x5"h
Nat. Ret. □ 20 mm R11 **P257**

137609 Bianco
137610 Cenere
137611 Taupe
137612 Grigio

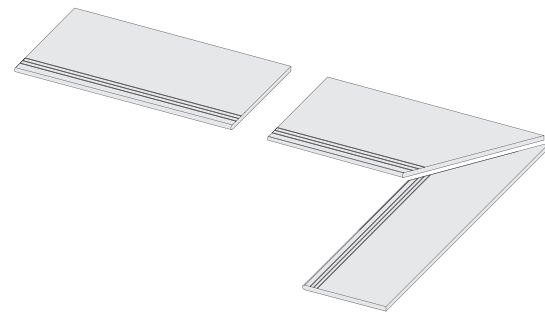
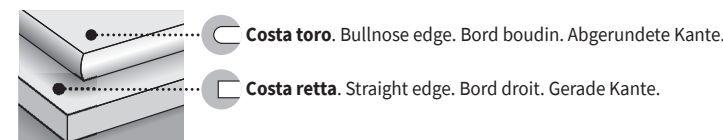

Gradone bordo grip . Large step with anti-slip border
Nez de marche avec antidérapant . Stufenplatten gerillt
40x120 . 16"x48"
Nat. Ret. □ 20 mm R11

P207	P227
Costa retta:	Costa toro:
137661 Bianco	137673 Bianco
137662 Cenere	137674 Cenere
137663 Taupe	137675 Taupe
137664 Grigio	137676 Grigio

Gradone bordo grip dx . Large step with anti-slip border
Nez de marche avec antidérapant . Stufenplatten gerillt
40x120 . 16"x48"
Nat. Ret. □ 20 mm R11

P225	P245
Costa retta:	Costa toro:
137665 Bianco	137677 Bianco
137666 Cenere	137678 Cenere
137667 Taupe	137679 Taupe
137668 Grigio	137680 Grigio

Gradone bordo grip sx . Large step with anti-slip border
Nez de marche avec antidérapant . Stufenplatten gerillt
40x120 . 16"x48"
Nat. Ret. □ 20 mm R11

P225	P245
Costa retta:	Costa toro:
137669 Bianco	137681 Bianco
137670 Cenere	137682 Cenere
137671 Taupe	137683 Taupe
137672 Grigio	137684 Grigio

Gradone bordo grip . Large step with anti-slip border
Nez de marche avec antidérapant . Stufenplatten gerillt
40x80 . 16"x31 ½"
Nat. Ret. □ 20 mm R11

P159	P171
Costa retta:	Costa toro:
137685 Bianco	137697 Bianco
137686 Cenere	137698 Cenere
137687 Taupe	137699 Taupe
137688 Grigio	137700 Grigio

Gradone bordo grip dx . Large step with anti-slip border
Nez de marche avec antidérapant . Stufenplatten gerillt
40x80 . 16"x31 ½"
Nat. Ret. □ 20 mm R11

P177	P189
Costa retta:	Costa toro:
137689 Bianco	137701 Bianco
137690 Cenere	137702 Cenere
137691 Taupe	137703 Taupe
137692 Grigio	137704 Grigio

Gradone bordo grip sx . Large step with anti-slip border
Nez de marche avec antidérapant . Stufenplatten gerillt
40x80 . 16"x31 ½"
Nat. Ret. □ 20 mm R11

P177	P189
Costa retta:	Costa toro:
137693 Bianco	137705 Bianco
137694 Cenere	137706 Cenere
137695 Taupe	137707 Taupe
137696 Grigio	137708 Grigio

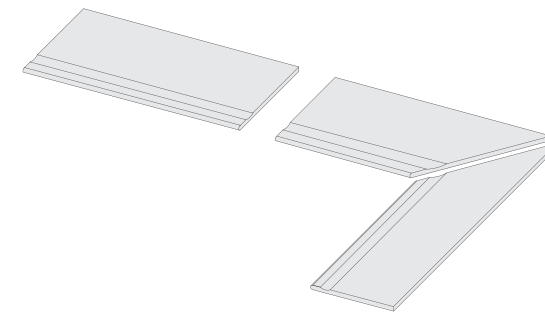

Gradone bordo svasato . Large step with rounded border
Nez de marche bord boudin . Stufenplatten gerippt
40x120 . 16"x48"
Nat. Ret. □ 20 mm R11

P295	P311
Costa retta:	Costa toro:
137709 Bianco	137721 Bianco
137710 Cenere	137722 Cenere
137711 Taupe	137723 Taupe
137712 Grigio	137724 Grigio

Gradone bordo svasato dx . Large step with rounded border
Nez de marche bord boudin . Stufenplatten gerippt
40x120 . 16"x48"
Nat. Ret. □ 20 mm R11

P305	P321
Costa retta:	Costa toro:
137713 Bianco	137725 Bianco
137714 Cenere	137726 Cenere
137715 Taupe	137727 Taupe
137716 Grigio	137728 Grigio

Gradone bordo svasato sx . Large step with rounded border
Nez de marche bord boudin . Stufenplatten gerippt
40x120 . 16"x48"
Nat. Ret. □ 20 mm R11

P305	P321
Costa retta:	Costa toro:
137717 Bianco	137729 Bianco
137718 Cenere	137730 Cenere
137719 Taupe	137731 Taupe
137720 Grigio	137732 Grigio

Gradone bordo svasato . Large step with rounded border
Nez de marche bord boudin . Stufenplatten gerippt
40x80 . 16"x31 ½"
Nat. Ret. □ 20 mm R11

P235	P257
Costa retta:	Costa toro:
137733 Bianco	137745 Bianco
137734 Cenere	137746 Cenere
137735 Taupe	137747 Taupe
137736 Grigio	137748 Grigio

Gradone bordo svasato dx . Large step with rounded border
Nez de marche bord boudin . Stufenplatten gerippt
40x80 . 16"x31 ½"
Nat. Ret. □ 20 mm R11

P253	P271
Costa retta:	Costa toro:
137737 Bianco	137749 Bianco
137738 Cenere	137750 Cenere
137739 Taupe	137751 Taupe
137740 Grigio	137752 Grigio

Gradone bordo svasato sx . Large step with rounded border
Nez de marche bord boudin . Stufenplatten gerippt
40x80 . 16"x31 ½"
Nat. Ret. □ 20 mm R11

P253	P271
Costa retta:	Costa toro:
137741 Bianco	137753 Bianco
137742 Cenere	137754 Cenere
137743 Taupe	137755 Taupe
137744 Grigio	137756 Grigio

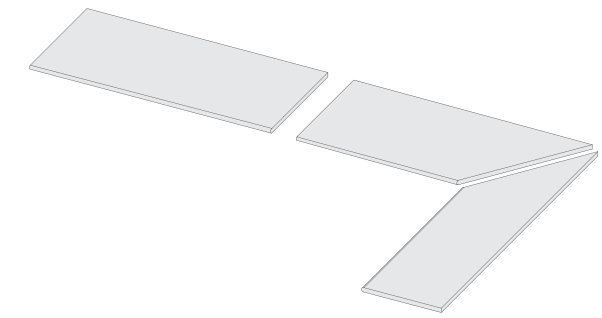

Gradone bordo 40 . Large step 40
Nez de marche avec bord 40 . Stufenplatten 40
40x120 . 16"x48"
Nat. Ret. □ 20 mm R11

P185	P203
Costa retta:	Costa toro:
137613 Bianco	137625 Bianco
137614 Cenere	137626 Cenere
137615 Taupe	137627 Taupe
137616 Grigio	137628 Grigio

Gradone bordo 40 dx . Large step 40
Nez de marche avec bord 40 . Stufenplatten 40
40x120 . 16"x48"
Nat. Ret. □ 20 mm R11

P203	P221
Costa retta:	Costa toro:
137617 Bianco	137629 Bianco
137618 Cenere	137630 Cenere
137619 Taupe	137631 Taupe
137620 Grigio	137632 Grigio

Gradone bordo 40 sx . Large step 40
Nez de marche avec bord 40 . Stufenplatten 40
40x120 . 16"x48"
Nat. Ret. □ 20 mm R11

P203	P221
Costa retta:	Costa toro:
137621 Bianco	137633 Bianco
137622 Cenere	137634 Cenere
137623 Taupe	137635 Taupe
137624 Grigio	137636 Grigio

Gradone bordo 40 . Large step 40
Nez de marche avec bord 40 . Stufenplatten 40
40x80 . 16"x31 ½"
Nat. Ret. □ 20 mm R11

P143	P155
Costa retta:	Costa toro:
137637 Bianco	137649 Bianco
137638 Cenere	137650 Cenere
137639 Taupe	137651 Taupe
137640 Grigio	137652 Grigio

Gradone bordo 40 dx . Large step 40
Nez de marche avec bord 40 . Stufenplatten 40
40x80 . 16"x31 ½"
Nat. Ret. □ 20 mm R11

P161	P173
Costa retta:	Costa toro:
137641 Bianco	137653 Bianco
137642 Cenere	137654 Cenere
137643 Taupe	137655 Taupe
137644 Grigio	137656 Grigio

Gradone bordo 40 sx . Large step 40
Nez de marche avec bord 40 . Stufenplatten 40
40x80 . 16"x31 ½"
Nat. Ret. □ 20 mm R11

P161	P173
Costa retta:	Costa toro:
137645 Bianco	137657 Bianco
137646 Cenere	137658 Cenere
137647 Taupe	137659 Taupe
137648 Grigio	137660 Grigio

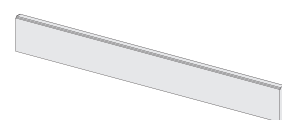
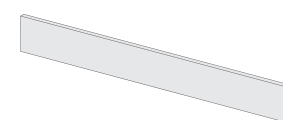

Alzata . Riser
Contremarche . Stoßfläche
20x120 . 8"x48"
Nat. Ret. □ 20 mm R11 **P101**

137501 Bianco
137502 Cenere
137503 Taupe
137504 Grigio

Alzata con scuretto . Riser with shutter
Contremarche avec cannelure . Stoßfläche mit Falzbearbeitung
20x120 . 8"x48"
Nat. Ret. □ 20 mm R11 **P151**

137509 Bianco
137510 Cenere
137511 Taupe
137512 Grigio

Alzata . Riser
Contremarche . Stoßfläche
20x80 . 8"x31 1/2"
Nat. Ret. □ 20 mm R11 **P077**

137505 Bianco
137506 Cenere
137507 Taupe
137508 Grigio

Alzata con scuretto . Riser with shutter
Contremarche avec cannelure . Stoßfläche mit Falzbearbeitung
20x80 . 8"x31 1/2"
Nat. Ret. □ 20 mm R11 **P139**

137513 Bianco
137514 Cenere
137515 Taupe
137516 Grigio

FORMATO Size	PZ. X SCAT. Pieces x box	MQ. X SCAT. Sqm x box	KG X SCAT. Weight x box
Battiscopa . Skirting 6,5x120 . 2 1/2"x48" □ Nat. Ret.	6	-	11,40
Gradino costa retta . Straight nosed stair 33x60x3,2h . 13"x24"x1 1/2"h □ Nat. Ret.	4	-	23,00
Gradino costa retta angolo dx/sx . Straight nosed corner step 33x60x3,2h . 13"x24"x1 1/2"h □ Nat. Ret.	2	-	12,00
Gradino costa retta . Straight nosed stair 33x80x3,2h . 13"x31 1/2"x1 1/2"h □ Nat. Ret. / □ Nat. Ret. R11	2	-	16,00
Gradino costa retta angolo dx/sx . Straight nosed corner step 33x80x3,2h . 13"x31 1/2"x1 1/2"h □ Nat. Ret. / □ Nat. Ret. R11	1	-	8,50
Gradino costa retta . Straight nosed stair 33x120x3,2h . 13"x48"x1 1/2"h □ Nat. Ret. / □ Nat. Ret. R11	2	-	23,00
Gradino costa retta angolo dx/sx . Straight nosed corner step 33x120x3,2h . 13"x48"x1 1/2"h □ Nat. Ret. / □ Nat. Ret. R11	1	-	12,00
Gradino piegato 30,5x34x5h . 12"x13 1/8"x2" ■ Nat. R11	6	-	15,00
Elemento a L 16x30,5x4,5h . 6 1/4"x12"x1 3/4"h ■ Nat. R11	6	-	8,00
Alzata . Riser 20x120 . 8"x48" □ Nat. Ret. 20 mm R11	1	-	8,00
Alzata . Riser 20x80 . 8"x31 1/2" □ Nat. Ret. 20 mm R11	1	-	6,00
Alzata con scuretto . Riser with shutter 20x120 . 8"x48" □ Nat. Ret. 20 mm R11	1	-	8,00
Alzata con scuretto . Riser with shutter 20x80 . 8"x31 1/2" □ Nat. Ret. 20 mm R11	1	-	6,00
Bordo L "A" . L-Shaped border "A" 10x120x10h . 4"x48"x4"h □ Nat. Ret. 20 mm R11	1	-	16,00
Bordo L "A" dx/sx . L-Shaped border "A" 10x120x10h . 4"x48"x4"h □ Nat. Ret. 20 mm R11	1	-	17,00
Bordo L "A" . L-Shaped border "A" 10x80x10h . 4"x31 1/2"x4"h □ Nat. Ret. 20 mm R11	1	-	11,00
Bordo L "A" dx/sx . L-Shaped border "A" 10x80x10h . 4"x31 1/2"x4"h □ Nat. Ret. 20 mm R11	1	-	12,00
Bordo L "B" . L-Shaped border "B" 10x120x10h . 4"x48"x4"h □ Nat. Ret. 20 mm R11	1	-	16,00
Bordo L "B" dx/sx . L-Shaped border "B" 10x120x10h . 4"x48"x4"h □ Nat. Ret. 20 mm R11	1	-	17,00
Bordo L "B" . L-Shaped border "B" 10x80x10h . 4"x31 1/2"x4"h □ Nat. Ret. 20 mm R11	1	-	8,00
Bordo L "B" dx/sx . L-Shaped border "B" 10x80x10h . 4"x31 1/2"x4"h □ Nat. Ret. 20 mm R11	1	-	9,00
Canalina . Channel 20x120x8h . 8"x48"x3"h □ Nat. Ret. 20 mm R11	1	-	18,00
Canalina dx/sx . Channel 20x120x8h . 8"x48"x3"h □ Nat. Ret. 20 mm R11	1	-	19,00
Canalina . Channel 20x80x8h . 8"x31 1/2"x3"h □ Nat. Ret. 20 mm R11	1	-	12,00
Canalina dx/sx . Channel 20x80x8h . 8"x31 1/2"x3"h □ Nat. Ret. 20 mm R11	1	-	13,00
Cordolo . U-Border 13x120x13h . 5"x48"x5"h □ Nat. Ret. 20 mm R11	1	-	18,00
Cordolo . U-Border dx/sx 13x120x13h . 5"x48"x5"h □ Nat. Ret. 20 mm R11	1	-	19,00
Cordolo . U-Border 13x80x13h . 5"x31 1/2"x5"h □ Nat. Ret. 20 mm R11	1	-	12,00
Cordolo dx/sx . U-Border 13x80x13h . 5"x31 1/2"x5"h □ Nat. Ret. 20 mm R11	1	-	13,00
Gradone bordo 40 . Large step 40x120 . 16"x48" □ Nat. Ret. 20 mm R11	1	-	21,50
Gradone bordo 40 dx/sx . Large step 40x120 . 16"x48" □ Nat. Ret. 20 mm R11	1	-	21,50
Gradone bordo 40 . Large step 40x80 . 16"x31 1/2" □ Nat. Ret. 20 mm R11	1	-	12,50
Gradone bordo 40 dx/sx . Large step 40x80 . 16"x31 1/2" □ Nat. Ret. 20 mm R11	1	-	12,50
Gradone bordo grip . Large step with anti-slip border 40x120 . 16"x48" □ Nat. Ret. 20 mm R11	1	-	21,50
Gradone bordo grip dx/sx . Large step with anti-slip border 40x120 . 16"x48" □ Nat. Ret. 20 mm R11	1	-	21,50
Gradone bordo grip . Large step with anti-slip border 40x80 . 16"x31 1/2" □ Nat. Ret. 20 mm R11	1	-	12,50
Gradone bordo svasato . Large step with rounded border 40x120 . 16"x48" □ Nat. Ret. 20 mm R11	1	-	21,50
Gradone bordo svasato dx/sx . Large step with rounded border 40x120 . 16"x48" □ Nat. Ret. 20 mm R11	1	-	21,50
Gradone bordo svasato . Large step with rounded border 40x80 . 16"x31 1/2" □ Nat. Ret. 20 mm R11	1	-	12,50
Gradone bordo svasato dx/sx . Large step with rounded border 40x80 . 16"x31 1/2" □ Nat. Ret. 20 mm R11	1	-	12,50
Griglia 20 . Drainage grid 20 20x60 . 8"x24" □ Nat. Ret. 20 mm R11	1	-	6,00
Griglia 20 dx/sx . Drainage grid 20 20x60 . 8"x24" □ Nat. Ret. 20 mm R11	1	-	5,50
Griglia 20 . Drainage grid 20 20x80 . 8"x31 1/2" □ Nat. Ret. 20 mm R11	1	-	8,00
Griglia 20 dx/sx . Drainage grid 20 20x80 . 8"x31 1/2" □ Nat. Ret. 20 mm R11	1	-	7,50

Imballaggi. Packages. Emballages. Verpackungen. Emballages. Упаковка.

FORMATO Size	PZ. X SCAT. Pieces x box	MQ. X SCAT. Sqm x box	KG X SCAT. Weight x box	EUROPALLET 80x120 cm			
				SCAT. X PAL. Boxes x pal.	MQ. X PAL. Sqm x pal.	KG X PAL. Weight x pal.	CM h PAL. cm h pal.
60x120 . 24"x48" □ Nat. Ret.	2	1,44	33,13	32	46,08	1.080	75
60x120 . 24"x48" □ Nat. Ret. R11	2	1,44	33,13	32	46,08	1.080	75
60x60 . 24"x24" □ Nat. Ret.	3	1,08	25,38	40	43,20	1.035	75
30x60 . 12"x24" □ Nat. Ret.	6	1,08	25,16	40	43,20	1.026	75
30,5x60,5 . 12"x24" ■ Nat.	8	1,48	33,96	32	47,36	1.107	75
Mosaico . Mosaic 30x30 . 12"x12" □ Nat. Ret.	6	0,54	13,00	54	29,16	722	75
Muretto 3D 15x61 . 6"x24" ■ Nat.	11	1,02	19,38	48	48,96	950	76
80x80 . 31 1/2"x31 1/2" □ Nat. Ret.	2	1,28	28,80	40	51,20	1.172	95
80x80 . 31 1/2"x31 1/2" □ Nat. Ret. R11	2	1,28	28,80	40	51,20	1.172	95
Simileuro 80x120							
80x80 . 31 1/2"x31 1/2" □ Nat. Ret. 20 mm R11	1	0,64	27,77	40	25,60	1.130	95
40x120 . 16"x48" □ Nat. Ret. 20 mm R11	2	0,96	43,00	24	23,04	1.052	75

I pesi riportati in tabella sono indicativi in quanto possono subire leggere variazioni per motivi produttivi. - The weights stated in the chart are approximate as some changes may be necessary for production reasons. - Les poids figurant dans le tableau sont fournis à titre indicatif car ils peuvent subir de légères variations pour des raisons de production. - Die in der Tabelle aufgeführten Gewichte sind nicht bindend, da sie aus Produktionsgründen leichte Änderungen aufweisen können. - Los pesos señalados en la tabla son aproximados ya que pueden experimentar ligeras variaciones por motivos productivos. - Указанный в таблице вес является приблизительным, так как ввиду производственных необходимости, он может слегка измениться.

Il peso dei PEZZI SPECIALI 20 mm indicato in tabella si riferisce al peso del singolo pezzo. Per calcolare il peso complessivo del materiale imballato occorrerà aggiungere al peso in tabella il peso dell'imballo e della paletta (peso variabile da 10 a 30 kg in funzione della quantità e della tipologia dei PEZZI SPECIALI richiesti). - The weight of the 20 mm TRIMS stated in the table refers to the weight of each trim. To calculate the total weight of the packed material, you will need to add the combined weight of the packing materials and the pallet (weight ranging from 10 to 30kg depending on the quantity and the type of the trims required) to the weight stated in the table. - Le poids des PIÈCES SPECIALES 20 mm indiqué dans le tableau se réfère au poids individuel de chaque pièce. Pour calculer le poids total du matériel emballé, il faudra ajouter au poids indiqué dans le tableau le poids de l'emballage et de la palette (poids variable de 10 à 30 kg en fonction de la quantité et du type de PIÈCES SPECIALES demandées). - Das in der Tabelle angegebene Gewicht der 20 mm-SONDERTEILE bezieht sich auf das Gewicht des Einzelteils. Zur Berechnung des Gesamtgewichts des verpackten Materials muss zum in der Tabelle aufgeführten Wert das Gewicht der Verpackung und der Palette (von 10 bis 30 kg variierbar in Abhängigkeit von der Menge und Art der gewünschten SONDERTEILE) dazugerechnet werden.

ISO 13006 - G - Bia (E ≤ 0,5%) UNI EN 14411 - G
GRES PORCELLANATO IN MASSA. FULL BODY PORCELAIN TILES. GRES CERAME PLEINE MASSE.
VOLLMASSE-FEINSTEINZEUG. PORCELÁNICO COMPACTO TODO MASA. ОДНОТОННЫЙ КЕРАМОГРАНИТ.

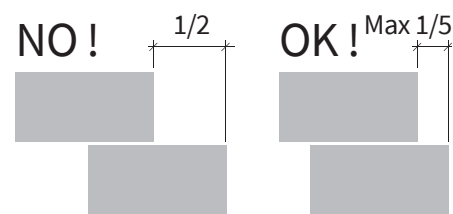

Si consiglia di mantenere una fuga di 2 mm per la posa in monoformato degli articoli rettificati.
Si consiglia di mantenere una fuga di 3 mm per la posa in multiformato (da 2 formati e oltre) degli articoli rettificati.
Si consiglia di mantenere una fuga di 4 mm per la posa degli articoli con bordi non rettificati.

If you are laying same sized straightened-edged tiles, we recommend you keep a 2 mm joint.
If you are laying different sized straightened-edged tiles (two or more sizes) together, we recommend you keep a 3 mm joint.
In the case of non-straightened-edged tiles, we recommend you keep a 4 mm joint.

On conseil de préserver un joint de 2 mm pour la pose en mon format des articles rectifiés.
On conseil de préserver un joint de 3 mm pour la pose en multiformat (de 2 formats et plus) des articles rectifiés.
On conseil de préserver un joint de 4 mm pour la pose des articles présentant des bords non rectifiés.

Es wird geraten, eine Fuge von 2 mm bei der Verlegung der geschliffenen Artikel im Einzelformat einzuhalten.
Es wird geraten, eine Fuge von 3 mm bei der Verlegung der geschliffenen Artikel als Multiformat (2 Formate und mehr) einzuhalten.
Es wird geraten, eine Fuge von 4 mm bei der Verlegung der Artikel mit ungeschliffenen Rändern einzuhalten.

Se aconseja mantener una junta de 2 mm para la colocación en monoformato de los artículos rectificadas.
Se aconseja mantener una junta de 3 mm para la colocación en multiformato (de 2 formatos o más) de los artículos rectificadas.
Se aconseja mantener una junta de 4 mm en la colocación de los artículos con bordes no rectificadas.

Рекомендуем оставлять межплиточный шов 2 мм при укладке обрезных изделий только одного формата.
Рекомендуем оставлять межплиточный шов 3 мм при укладке обрезных изделий нескольких (2 или более) форматов.
Рекомендуем оставлять межплиточный шов 4 мм при укладке изделий с необрезными кромками.

CARATTERISTICA SPECIFICATION CARACTERISTIQUE EIGENSCHAFT CARACTERÍSTICA СПЕЦИФИКА	METODO DI PROVA TEST METHODS METHODE D'ESSAI TESTVERFAHREN PRUEBA СТАНДАРТ ИСПЫТАНИЙ	VALORE PRESCRITTO GRES PORCELLANATO IN MASSA FIXED VALUE VALEUR PRESCRITE VORGESCHRIEBENER WERT VALOR PRESCRITO ТРЕБУЕМОЕ ЗНАЧЕНИЕ	 Civilization of Beauty		
CARATTERISTICHE DIMENSIONALI DIMENSIONAL CHARACTERISTICS - DIMENSIONS - DIMENSIONALE EIGENSCHAFTEN - CARACTERÍSTICAS DIMENSIONALES - ПРОСТРАНСТВЕННЫЕ ХАРАКТЕРИСТИКИ			NATURALE	RETTIFICATO	LAPPATO / RETTIFICATO
LUNGHEZZA E LARGHEZZA LENGTH AND WIDTH - LONGUER ET LARGEUR - LÄNGE UND BREITE LARGURA Y LARGUEZA - ДЛИНА И ШИРИНА		± 0,6 %			
SPESORE THICKNESS - EPAISSEUR - STÄRKE - ESPESOR - ТОЛЩИНА		± 5 %			
RETTILINEITÀ DEGLI SPIGOLI STRAIGHTNESS OF EDGES - RECTITUDE DES BORDS - RECHTCKEIGKEIT DER ECKEN - ORTOGONALIDAD DE LAS ESQUINAS - ПРЯМОЛИНЕЙНОСТЬ ГРАНИ		± 0,5 %			
ORTOGONALITÀ ORTHOGONALITY - ORTHOGONALITE - RECHTWINKLIGKEIT ORTOGONALIDAD - ПРЯМОУГОЛЬНОСТЬ	ISO 10545-2	± 0,5 %	CONFORME COMPLIANT CONFORME ERFÜLLT CUMPLE СООТВЕТСТВУЕТ	CONFORME COMPLIANT CONFORME ERFÜLLT CUMPLE СООТВЕТСТВУЕТ	CONFORME COMPLIANT CONFORME ERFÜLLT CUMPLE СООТВЕТСТВУЕТ
PLANARITÀ (Curvatura del centro - curvatura dello spigolo - svergolamento) PLANARITY (Curvature of centre - curvature of edge - bending) PLANARITÉ (Courbure du centre - courbure de l'arête - gauchissement) EBENHEIT (Krümmung der Mitte - Krümmung der Kante - Verdréhung) PLANEIDAD (Curvatura del centro - curvatura del canto - deformación) ЛИНЕЙНОСТЬ (Изгиб центра - изгиб кромки - перекося)		± 0,5 %			
QUALITÀ DELLA SUPERFICIE SURFACE QUALITY - QUALITE DE LA SURFACE - QUALITÄT DER OBERFLÄCHE CALIDAD DE LA SUPERFICIE - ПОВЕРХНОСТИ		95% DELLE PIASTRELLE ESENTI DA DIFETTI VISIBILI 95% OF TILES SHOW NO VISIBLE DEFECTS 95% DES CARREAUX SONT DÉPOURVUS DE DÉFAUTS VISIBLES 95% DER FLIESEN SIND FREI VON SICHTBAREN FEHLERN 95 % DE LAS BALDOS ASIENTOS DE DEFECTOS VISIBLES TAL 95% ПЛИТКИ НЕ ИМЕЕТ ВИДИМЫХ ДЕФЕКТОВ В			
ASSORBIMENTO D'ACQUA WATER ABSORPTION - ABSORPTION D'EAU - WASSERAUFNAHME ABSORCIÓN DE AGUA - ВОДОПОГЛАЩЕНИЕ	ISO 10545-3	≤ 0,5 %	CONFORME - COMPLIANT CONFORME - ERFÜLLT CUMPLE - СООТВЕТСТВУЕТ		
RESISTENZA ALLA FLESSIONE BREAKING MODULUS - RESISTANCE A LA FLEXION - BIEGEFESTIGKEIT RESISTENCIA A LA FLEXION - ПРОЧНОСТЬ НА ИЗГИБ	ISO 10545-4	35 N/mm ²	CONFORME - COMPLIANT CONFORME - ERFÜLLT CUMPLE - СООТВЕТСТВУЕТ		
SFORZO DI ROTTURA MODULUS OF RUPTURE - CHARGE DE RUPTURE - BRUCHLAST ESFUERZO DE ROTURA - СТОЙКОСТЬ НА ИЗГИБ		SPESORE - THICKNESS EPAISSEUR - STÄRKE ESPESOR - ТОЛЩИНА ≥ 7,5 mm: min. 1300 N < 7,5 mm: min. 700 N	CONFORME - COMPLIANT CONFORME - ERFÜLLT CUMPLE - СООТВЕТСТВУЕТ		
DETERMINAZIONE DELLA RESISTENZA A FLESSIONE E CARICO DI ROTTURA DETERMINATION OF BREAKING MODULUS AND MODULUS OF RUPTURE - DETERMINATION DE LA RESISTANCE A LA FLEXION ET A LA CHARGE DE RUPTURE - BESTIMMUNG DER BIEGEFESTIGKEIT UND DER BRUCHLASTBESTÄNDIGKEIT - DETERMINACION DE LA RESISTENCIA A FLEXION Y CARGA DE ROTURA ОПРЕДЕЛЕНИЕ ПРОЧНОСТИ НА ИЗГИБ И РАЗРУШАЮЩЕЙ НАГРУЗКИ	UNI EN 1339:2005 / COR. 2011 ANNEX F	SPESORE - THICKNESS EPAISSEUR - STÄRKE ESPESOR - ТОЛЩИНА 20 mm	SPESORE 20 mm	CLASSE U11	
RESISTENZA ALL'ABRASIONE PROFONDA DEEP ABRASION RESISTANCE - RESISTANCE A L'ABRASION PROFONDE - BESTÄNDIGKEIT GEGEN TIEFENVERSCHEIB - RESISTENCIA A LA ABRASION PROFUNDA - УСТОЙЧИВОСТЬ К ГЛУБОКОМУ СТИРАНИЮ ПО	ISO 10545-6	≤ 175 mm ³	CONFORME - COMPLIANT CONFORME - ERFÜLLT CUMPLE - СООТВЕТСТВУЕТ		
COEFFICIENTE DI DILATAZIONE TERMICA LINEARE THERMAL EXPANSION COEFFICIENT - COEFFICIENT DE DILATATION THERMIQUE LINEAIRE WARMEAUSSAHNUNGSKOEFFIZIENT - COEFFICIENTE DE DILATACION TERMICA LINEAL ЗКОЭФФИЦИЕНТ ТЕПЛООВОГО ЛИНЕЙНОГО РАСТИРЕНИЯ	ISO 10545-8	METODO DISPONIBILE AVAILABLE ON REQUEST METHODE DISPONIBLE VERFÜGBARES VERFAHREN METODO DISPONIBILE ОПРЕДЕЛЯЕТСЯ ПРОИЗВОДИТЕЛЕМ	≤ 7x10 ⁻⁶ °C ⁻¹		
RESISTENZA AGLI SBALZI TERMICI THERMAL SHOCK RESISTANCE - RESISTANCE AUX ECARTS DE TEMPERATURE TEMPERATURWECHSELBESTÄNDIGKEIT - RESISTENCIA A CHOQUE TÉRMICO УСТОЙЧИВОСТЬ К ТЕМПЕРАТУРНЫМ ПЕРЕПАДАМ	ISO 10545-9	METODO DISPONIBILE AVAILABLE ON REQUEST METHODE DISPONIBLE VERFÜGBARES VERFAHREN METODO DISPONIBILE ОПРЕДЕЛЯЕТСЯ ПРОИЗВОДИТЕЛЕМ	RESISTENTI - RESISTANT RESISTANTS - WIDERSTANDSFÄHIG RESISTE - УСТОЙЧИВЫ		
RESISTENZA AL GELO FROST RESISTANCE - RESISTANCE AU GEL - FROSTBESTÄNDIGKEIT RESISTENCIA AL HIELO - МОРОЗОСТОЙКОСТЬ	ISO 10545-12	RICHIESTA - ALWAYS TESTED EXIGEE - NOTWENDIG PEDIDO - ТРЕБОВАНИЯ	RESISTENTI - RESISTANT RESISTANTS - WIDERSTANDSFÄHIG RESISTE - УСТОЙЧИВЫ		
PRODOTTI CHIMICI AD USO DOMESTICO ED ADDITIVI PER PISCINA HOUSEHOLD CHEMICALS AND SWIMMING POOL WATER CLEANSERS - PRODUITS CHIMIQUES COURANTS ET ADDITIFS POUR PISCINE - CHEM.PRODUKTE FÜR DEN HAUSHALTSGEBRAUCH UND ZUSATZ FÜR SCHWIMMBÄDER - PRODUCTOS QUÍMICOS PARA USO DOMÉSTICO Y CON ADITIVOS PARA PISCINA - БЫТОВЫЕ ХИМИЧЕСКИЕ СРЕДСТВА И СРЕДСТВА ДЛЯ БАССЕЙНОВ		min. UB		UA	
ACIDI ED ALCALI A BASSA CONCENTRAZIONE ACIDS AND LOW CONCENTRATION ALKALIS - ACIDES ET ALCALI A FAIBLE CONCENTRATION - SAÜREN UND ALKALI IN GERINGER KONZENTRATION - ÁCIDOS Y ALCALIS EN BAJA CONCENTRACION - НИЗКОКОНЦЕНТРИРОВАННЫЕ КИСЛОТЫ И ЩЕЛОЧИ	ISO 10545-13	COME DICHIARATO DAL PRODUTTORE AS DECLARED BY THE MANUFACTURER COMME LE DECLARE LE PRODUCTEUR WIE VOM HERSTELLER ERKLÄRT COMO DECLARA EL FABRICANTE СООТВЕТСТВИИ С ЗАЯВЛЕНИЯМИ ПРОИЗВОДИТЕЛЯ	RESISTENTI RESISTANT RESISTANTS WIDERSTANDSFÄHIG RESISTE УСТОЙЧИВЫ		
ACIDI ED ALCALI AD ALTA CONCENTRAZIONE ACIDS AND HIGH CONCENTRATION ALKALIS - ACIDES ET ALCALI A FORTE CONCENTRATION SAÜREN UND ALKALI IN HOHER KONZENTRATION - ÁCIDOS Y ALCALIS EN ALTA CONCENTRACION - ВЫСОКОКОНЦЕНТРИРОВАННЫЕ КИСЛОТЫ И ЩЕЛОЧИ		METODO DISPONIBILE AVAILABLE ON REQUEST METHODE DISPONIBLE VERFÜGBARES VERFAHREN METODO DISPONIBILE ОПРЕДЕЛЯЕТСЯ ПРОИЗВОДИТЕЛЕМ	RESISTENTI RESISTANT RESISTANTS WIDERSTANDSFÄHIG RESISTE УСТОЙЧИВЫ		
RESISTENZA ALLE MACCHIE STAIN RESISTANCE - RESISTANCE AUX TACHES - FLECKBESTÄNDIGKEIT RESISTENCIA A LAS MANCHAS - УСТОЙЧИВОСТЬ К ЗАГРЯЗНЕНИЮ	ISO 10545-14	METODO DISPONIBILE AVAILABLE ON REQUEST METHODE DISPONIBLE VERFÜGBARES VERFAHREN METODO DISPONIBILE ОПРЕДЕЛЯЕТСЯ ПРОИЗВОДИТЕЛЕМ	RESISTENTI RESISTANT RESISTANTS WIDERSTANDSFÄHIG RESISTE УСТОЙЧИВЫ		
STABILITÀ DEI COLORI ALLA LUCE COLOUR STABILITY TO LIGHT - STABILITE DES COULEURS A LA LUMIERE - LICHTECHTHEIT DER FARBEN - ESTABILIDAD DE LOS COLORES - УСТОЙЧИВОСТЬ ЦВЕТА	DIN 51094	NON DEVONO PRESENTARE APPREZZABILI VARIAZIONI DI COLORE THEY DO NOT HAVE TO SHOW VISIBLE COLOUR ALTERATION PAS DE MODIFICATIONS SENSIBLES DE COULEUR WEISEN KEINE SICHTBAREN FARBÄNDERUNGEN AUF NO DEBEN PRESENTAR VARIACIONES DE COLOR APPRECIABLES НЕ ДОЛЖНЫ ИМЕТЬ ЗАМЕТНЫХ РАЗЛИЧИЙ ЦВЕТА	CONFORME COMPLIANT CONFORME ERFÜLLT CUMPLE СООТВЕТСТВУЕТ		
COEFFICIENTE DI ATTRITO (SCIVOLosità) FRICTION COEFFICIENT (SLIP RISK) COEFFICIENT DE FROTTEMENT (GLISSANCE) REIBUNGSKOEFFIZIENT (GLATTE) COEFFICIENTE DE FRICCIÓN (DESIZABILIDAD) КОЭФФИЦИЕНТ ТРЕНИЯ (СКОЛЬЗКОСТЬ)	DIN 51097 D.M.236/89 B.C.R. ANSI A 137.1:2012	DOVE RICHIESTO IF NEEDED SI DEMANDE NACH ANFRAGE SI REQUERIDO DE SELEDVET	A RICHIESTA AVAILABLE ON REQUEST SUR DEMANDE AUF ANFRAGE BAJO PEDIDO ПО ЗАПРОСУ		

Certificazioni di prodotto. Product certification. Certification de produit.
Produkt Zertifizierungen. Certificaciones de producto. Сертификация.

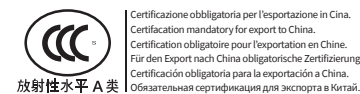

Certificazione obbligatoria per l'esportazione in Cina.
Certification mandatory for export to China.
Certification obligatoire pour l'exportation en Chine.
Für den Export nach China obligatorische Zertifizierung.
Certificación obligatoria para la exportación a China.
Обязательная сертификация для экспорта в Китай.



100%
DESIGN AND PRODUCTION
OF ITALY



Azienda Certificata
Certified Company



Distribuitoar în România - Gada Ceramic București
Str. Vlad Județu 48
<https://gadaceramic.ro/produs/gresie-ardesia/>

Le cromie, le strutture e le grafiche delle piastrelle riprodotte nelle immagini del catalogo potrebbero non corrispondere fedelmente al prodotto industriale.
The colours, structures, and patterns of the tiles illustrated in the catalogue might not correspond exactly to the actual product.
Les tonalités, les structures et les graphismes des carreaux reproduits sur les images du catalogue pourraient ne pas correspondre idèlement au produit industriel.
Es ist möglich, dass die im Katalog abgebildeten Fliesen in Bezug auf Farbton, Struktur und Grafik vom Industrieerzeugnis abweichen.
Las estructuras, los colores y las gráficas de las baldosas reproducidas en las imágenes del catálogo podrían no coincidir fielmente con el producto industrial.
Описание оттенков цвета, структура и графическое изображение на плитках, которые напечатаны в каталоге могут не соответствовать действительному промышленному продукту.

La Fabbrica S.p.A. si riserva di apportare, senza alcun preavviso, le modifiche che riterrà più opportune al fine di migliorare il prodotto.
Quanto riportato è da considerarsi indicativo e non esaustivo in riferimento ai colori e alle caratteristiche estetiche dei prodotti.
La Fabbrica S.p.A. reserves the right to make any changes it deems fit in order to improve the product, without prior notice.
All images are provided for illustrative purposes only and other colours and aesthetic features are available.
La Fabbrica S.p.A. se réserve le droit d'apporter, sans préavis, les modifications qu'elle jugera opportunes afin d'améliorer le produit.
Les informations ci-dessus sont fournies à titre indicatif et elles ne sont pas contraignantes en ce qui concerne les couleurs et les caractéristiques esthétiques des produits.
Die Firma La Fabbrica S.p.A. behält sich vor, ohne jegliche vorherige Ankündigung jene Änderungen vorzunehmen, die sie zur Verbesserung des Produktes für angebracht hält.
Die Angaben sind bezüglich der Farben und ästhetischen Eigenschaften der Produkte als Richtwerte und nicht als vollständig anzusehen.
La Fabbrica S.p.A. se reserva la posibilidad de introducir, sin obligación de aviso previo, las modificaciones que considere más indicadas para mejorar el producto.
Las cualidades del material presentado deben considerarse de modo genérico, no siendo exhaustivas en cuanto a los colores y a las características estéticas de los productos.
La Fabbrica S.p.A. оставляет за собой право на внесение без предварительного уведомления изменений, которые она считает целесообразными для улучшения продукции.
Приведенные указания должны считаться ориентировочными и не исчерпывающими в том, что касается цветов и эстетических характеристик продукции.

Distribuitor în România - Gada Ceramic București
Str. Vlad Județu 48
<https://gadaceramic.ro/produs/gresie-ardesia/>

CAT137019



Civilization of Beauty

La Fabbrica S.p.A.
Via Emilia Ponente, 925
48014 Castel Bolognese (RA) Italy
Tel. +39 0546 - 659911 - Fax +39 0546 - 656223
www.lafabbrica.it - info@lafabbrica.it

A company part of



FOLLOW US

